



深圳大夏龙雀科技有限公司

Shenzhen DX-SMART Technology Co Ltd.

DX-BT04-E05/E06蓝牙模块

DX-BT04-E05/E06 Bluetooth Module

[\(英文技术手册请跳转到第19页\)](#)

[Note: English instructions go to page 19](#)

技 术 手 册



目录

一、概述.....	3
二、默认参数.....	3
三、应用领域:	4
四、功耗参数:	5
五、射频特性.....	5
六、透传参数.....	5
七、模块引脚说明及最小电路图.....	6
八、管脚功能描述:	7
九、其他配置.....	8
十、外形尺寸:	8
十一、LAYOUT 注意事项.....	9
十二、 BT04-E06 AT 指令集.....	9
1、测试指令:	9
2、设置/查询设备名称:	9
3、设置/查询一配对码:	10
4、设置/查询一串口波特率:	10
5、获取软件版本号:	10
6、模块复位(重启):	11
7、恢复默认状态:	11
8、查询一蓝牙地址码:	11
9、查询/设置一服务SERVICE UUID.....	11
10、查询/设置一 NOTIFY UUID\ READ UUID.....	11
11、查询/设置一 WRITE UUID.....	12
12、查询/设置一广播间隔.....	12
13. 校验设置指令.....	13
十三、 BT04-E05 AT 指令集.....	13
1、测试指令: (34 脚置高一次).....	13
2、模块复位(重启): (34 脚置高一次).....	13
3、获取软件版本号: (34 脚一直置高).....	14
4、恢复默认状态: (34 脚置高一次).....	14
5、查询一蓝牙地址码:	14
6、设置/查询设备名称: (34 脚一直置高).....	14
7、设置/查询一配对码: (34 脚置高一次).....	15
8、设置/查询一串口参数 (34 脚置高一次).....	15
9、设置 PIO 单端口输出 (34 脚置高一次).....	16
10、查询/设置一服务SERVICE UUID.....	16
11、查询/设置一 NOTIFY UUID\ READ UUID.....	16
12、查询/设置一 WRITE UUID.....	17
13、查询/设置一广播间隔.....	17
十四、联系我们.....	17



一、概述

DX-BT04-E05/E06 蓝牙模块是深圳大夏龙雀科技有限公司专为智能无线数据传输而打造，SPP+BLE双模蓝牙。

本模块支持 UART 接口；并支持 SPP3.0+BLE4.2蓝牙串口协议，具有成本低、体积小、功耗低、收发灵敏性高等优点，只需配备少许的外围元件就能实现其强大功能。

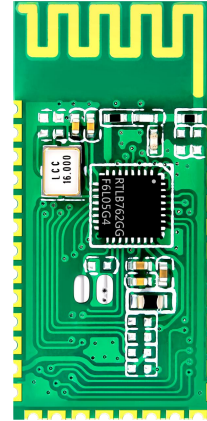

二、默认参数

蓝牙协议	Bluetooth Specification V3.0 SPP +V4.2 BLE
工作频率	2.4GHz ISM band
通信接口	UART
供电电源	MIN:1.8V - MAX:3.6V (建议3.3V)
天线	PCB板载天线
通信距离	30-40M (空旷环境)
外观尺寸	27mm x 13mm x 2 mm
蓝牙认证	ROHS REACH FCC
蓝牙名称	BT04-E05/E06(可定制)
配对码	1234 (SPP协议有效)
串口参数	9600、8数据位、1停止位、无校验、无流控
Service UUID	FFE0
Notify UUID	FFE1
Write UUID	FFE2
Storage temperature	MIN:-40°C - MAX:+140°C
Work temperature	MIN:-20°C - MAX:+85°C
定制需求	如有其它特殊功能要求，可以联系我司，对模块进行定制



三、应用领域：

该模块主要用于短距离的数据无线传输领域。可以方便的和手机、PC 机的蓝牙设备相连，避免繁琐的线缆连接，能直接替代串口线。

- ※ 蓝牙无线数据传输
- ※ 工业遥控、遥测
- ※ POS 系统
- ※ 交通、报警
- ※ 自动化数据采集系统
- ※ 无线数据传输；银行系统
- ※ 无线数据采集
- ※ 楼宇自动化、安防、机房设备无线监控、门禁系统；
- ※ 智能家居、工业控制；
- ※ 医疗器械
- ※ 电子秤
- ※ 蓝牙打印机、喵喵机
- ※ 蓝牙遥控玩具
- ※ 汽车检测设备
- ※ 汽车诊断仪 OBDII



四、功耗参数：

DC-DC	Average Current	Unit
Discoverable	4	mA
Connected(BLE)	4	mA
Connected(SPP)	9	mA

五、射频特性

Rating	Value	Unit
Basic Rate 发射功率	0	dBm
Basic Rate 灵敏度	-90	dBm
BLE 发射功率	0	dBm
BLE 灵敏度	-93	dBm

六、透传参数

BT04-E05/E06 双模 SPP 数据吞吐量：

Android ->BT04-E05/E06 -> UART	UART ->BT04-E05/E06 -> Android	BAUD
11500 bytes/s	4500 bytes/s	115200

BT04-E05/E06 双模 BLE 数据吞吐量：

IPhone 6 ->BT04-E05/E06 -> UART		UART ->BT04-E05/E06 -> IPhone 6	
波特率	115200	波特率	115200
连接间隔时间(ms)	15	连接间隔时间(ms)	15
APP 数据包大小(bytes)	80	串口数据包大小(bytes)	80
发送间隔(ms)	50	发送间隔(ms)	70
吞吐量(bytes/s)	4500	吞吐量(bytes/s)	2500
Characteristic 写方式	Write without Response	Characteristic 通知方式	Notify



七、模块引脚说明及最小电路图

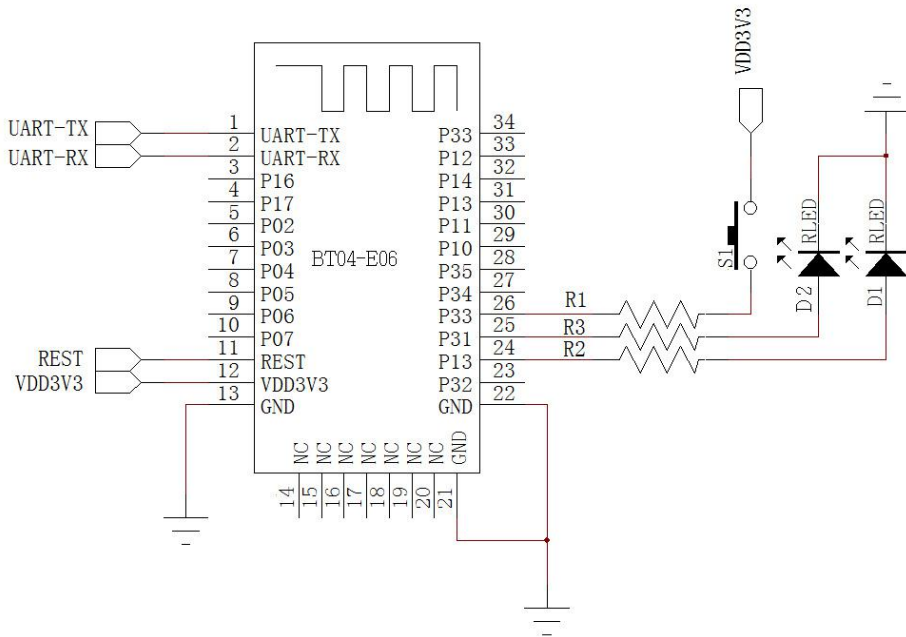
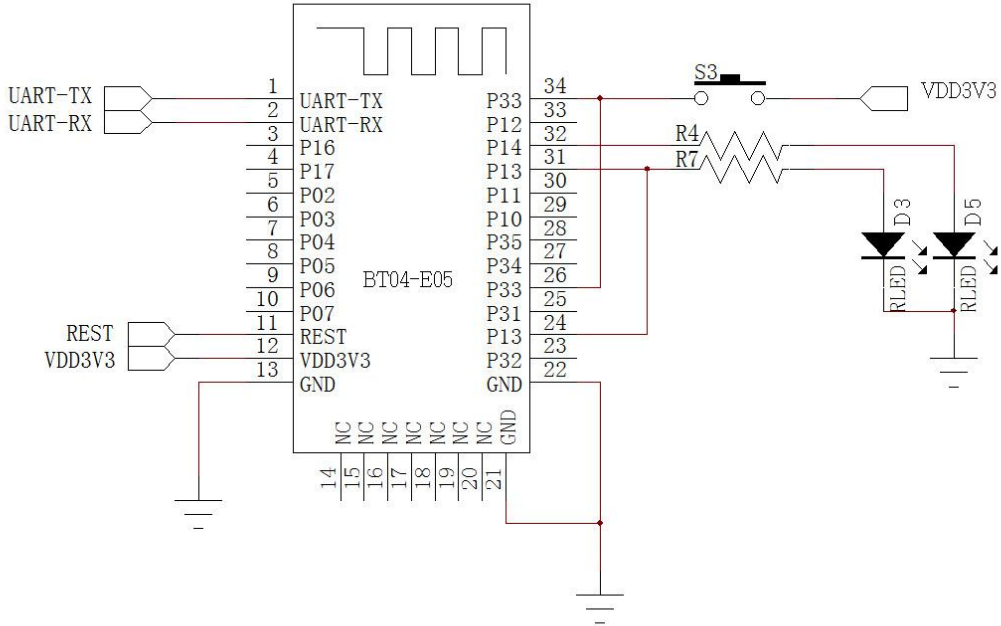

注意：该应用电路图为蓝牙串口电路，如需要其他应用方案，请联系我们



八、管脚功能描述:

管脚号	名称	类型	功能描述
1	UART-TX	CMOS 输出	串口数据输出
2	UART-RX	CMOS 输入	串口数据输入
3	NC	双向	NC (请悬空)
4	NC	双向	NC (请悬空)
5	P02	双向	可编程输入/输出口
6	P03	双向	可编程输入/输出口
7	P04	双向	可编程输入/输出口
8	P05	双向	可编程输入/输出口
9	P06	双向	可编程输入/输出口
10	P07	双向	可编程输入/输出口
11	RESET	CMOS 输入	复位/重启键 (低电平复位)
12	VCC	电源输入	+3.3V 电源
13	GND	地	地
14	NC	双向	NC (请悬空)
15	NC	双向	NC (请悬空)
16	NC	双向	NC (请悬空)
17	NC	双向	NC (请悬空)
18	NC	双向	NC (请悬空)
19	NC	双向	NC (请悬空)
20	NC	双向	NC (请悬空)
21	GND	地	地
22	GND	地	地
23	P32	双向	NC (请悬空)
24	P31	输出	模块状态指示口 (BT04-E06有效)
25	P13	输出	模块断开指示口 (BT04-E06有效)
26	P33	双向	默认接地, 拉高进入AT模式 (BT04-E05有效)
27	P34	双向	可编程输入/输出口
28	P35	双向	可编程输入/输出口
29	P10	双向	可编程输入/输出口
30	P11	双向	可编程输入/输出口



31	P13	双向	模块状态指示口 (BT04-E05有效)
32	P14	双向	模块断开指示口 (BT04-E05有效)
33	P12	双向	NC (请悬空)
34	KEY	双向	进入AT指令模式 (详见AT指令集说明, BT04-E05有效)

九、其他配置

状态指示 LED: P13

用于指示蓝牙模块所处状态, LED 灯闪烁方式与蓝牙模块状态对应见下表:

模式	LED 显示	模块状态
待机	均匀慢速闪烁 (500ms-on, 500ms-off)	等待配对
	长亮	建立连接

蓝牙模块断开指示: P31

用于指示蓝牙模块连接与否, 连接状态为高电平, 其他状态低电平。

十、外形尺寸:

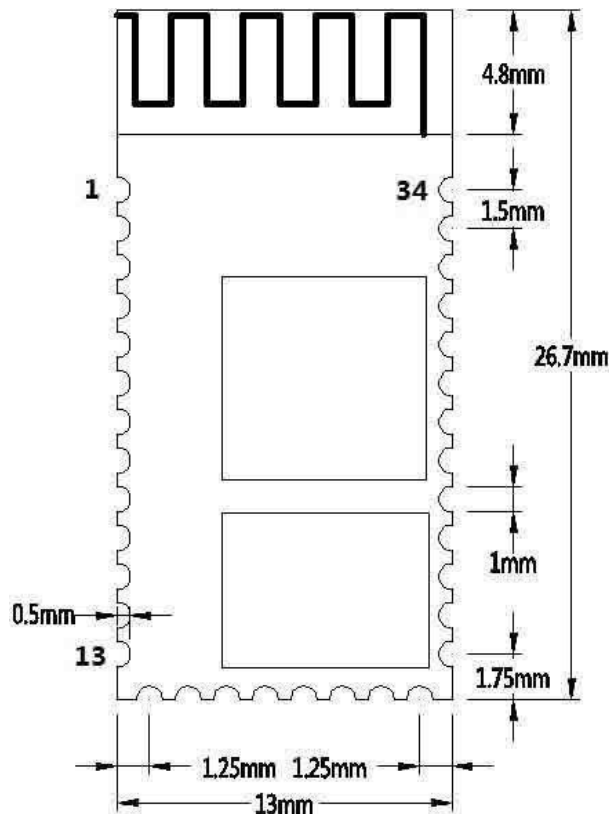



十一、LAYOUT 注意事项

- 1、DX-BT04-E05/E06 蓝牙模块串口电平需 3.3V，如果和 5V 电平系统连接需要增加电平转换芯片。
- 2、蓝牙信号受周围影响很大，如树木、金属、墙体等障碍物会对蓝牙信号有一定的吸收或屏蔽，所以建议不要安装在金属外壳之中。
- 3、由于金属会削弱天线功能，建议在给模块 Lay 板时，模块天线下面不要铺地和走线，最好能挖空。

十二、 BT04-E06 (HC06) AT 指令集

用户可以通过串口和DX-BT04-E05/E06蓝牙模块进行通信，串口使用Tx, Rx 两根信号线
波特率支持2400, 4800, 9600, 19200, 38400, 57600, 115200bps
串口默认波特率为9600bps

指令集详细说明（**模块未连接时为 AT 模式，连接上后为透传模式**）

DX-BT04-E05/E06 蓝牙串口模块指令为 Command 指令集。

（注：给模块上电，不配对的情况下，就是 AT 模式了，AT指令只能在模块未连接状态下才能生效，一旦蓝牙模块与设备连接上，蓝牙模块即进入数据透传模式。）

1、测试指令：

下行指令	响应	参数
AT	OK	无

2、设置/查询设备名称：

下行指令	响应	参数
AT+NAME	+NAME=<Param>	参数 name：所要设置的当前名称，即蓝牙被搜索到的名称。18 个字符以内。
AT+NAME<Param>	OKsetname	

例：修改蓝牙设备名为 1234

发送：AT+NAME1234

返回：OKsetname

这时蓝牙名称改为 1234

参数支持掉电保存。



3、设置/查询—配对码：

下行指令	响应	参数
AT+PIN	+PIN=<Param>	Param: 配对码默认名称: “1234”
AT+ PINxxxx	OKsetPIN	

改配对码为 8888 发送：

AT+PIN8888

返回：OKsetPIN

这时蓝牙配对密码改为 8888，模块默认配对密码是 1234。

参数支持掉电保存。

4、设置/查询—串口波特率：

下行指令	响应	参数
AT+BAUD	+BAUD=<Param>	2---2400
AT+BAUD2	OK2400	3---4800
		4---9600
		5---19200
		6---38400
		7---57600
		8---115200
		默认：4---9600

例：修改波特率为 38400

发送：AT+BAUD6

返回：OK38400

此时波特率为 38400

注意：波特率更改以后，如果不是默认的 9600，在以后参数设置或进行数据通信时，需使用所设置的波特率。

5、获取软件版本号：

下行指令	响应	参数
AT+VERSION	+VERSION=<Param>	Param: 软件版本号

举例说明：

AT+VERSION

+VERSION=2.0-20100601



6、模块复位（重启）：

下行指令	响应	参数
AT+RESET	OK	无

7、恢复默认状态：

下行指令	响应	参数
AT+DEFAULT	OK	无

8、查询—蓝牙地址码：

下行指令	响应	参数
AT+LADDR	+ LADDR =<Param>	Param:地址码

例：

发送：AT+LADDR

返回：+LADDR=11:22:33:44:55:66

11:22:33:44:55:66为查询所获取的实际地址码。

9、查询/设置—服务SERVICE UUID 默认:FFE0

下行指令	响应	参数
(查询) AT+UUID	+UUID=<Param>	Param: UUID号
(设置) AT+UUID<Param>	OK	

例：修改/查询服务UUID

发送：AT+UUID

返回：+UUID=FFE0

发送：AT+UUIDFFE1

返回：OK

注意：UUID设置以后，需要复位操作后设置才会生效。

10、查询/设置— NOTIFY UUID\ READ UUID 默认:FFE1

下行指令	响应	参数
(查询) AT+CHAR	+CHAR=<Param>	Param: UUID号
(设置) AT+CHAR<Param>	OK	

例：修改/查询 NOTIFY UUID\ READ UUID



发送: AT+CHAR

返回: +CHAR=FFE0

发送: AT+CHARFFE1

返回: OK

注意: UUID设置以后, 需要复位操作后设置才会生效。

11、查询/设置— WRITE UUID 默认: FFE2

下行指令	响应	参数
(查询) AT+WRITE	+WRITE=<Param>	Param: UUID号
(设置) AT+WRITE<Param>	OK	

例: 修改/查询写入WRITE UUID 发

送: AT+WRITE

返回: +WRITE=FFE2

发送: AT+WRITEFFE1

返回: OK

注意: UUID设置以后, 需要复位操作后设置才会生效。

12、查询/设置—广播间隔 默认: 0

下行指令	响应	参数
(查询) AT+ADVI	+ADVI=<Param>	Param: 广播间隔 0—100ms 1—152.5ms 2—211.25ms 3—318.75ms 4—417.5ms 5—546.25ms 6—760ms 7—852.5ms 8—1022.5ms 9—1285ms A—2000ms B—3000ms C—4000ms D—5000ms E—6000ms F—7000ms 默认设置: 0
(设置) AT+ADVI<Param>	+ADVI=<Param> OK	



例：修改/查询广播间隔

发送：AT+ADVI

返回：+AVDI=0

发送：AT+AVID1

返回：+AVDI=1 OK

(对应152.5ms)

注意：广播间隔设置以后，需要复位操作后才会生效。

13. 校验设置指令

下行指令	响应	参数
AT+PN	OK None	无校验：模块默认即为无校验
AT+PE	OK Even	偶校验：模块为偶校验位
AT+PO	OK Odd	奇校验：模块为奇校验位

十三、BT04-E05 (HC05) AT 指令集

模块进入 AT 模式的方法

1、模块上电，未配对情况下就是 AT 模式，波特率为模块本身的波特率，默认：9600，发送 AT 指令时需要置高一次 PI033。

2、PI033 置高电平后，再给模块上电，此时模块进入 AT 模式，波特率固定为：38400，可以直接发送 AT 指令

(注：1、当用户忘记模块本身波特率时，使用第二种方法固定为 38400，平时建议用户使用第一种方法进入 AT 模式！

2、不带底板的模块上电即为方法2的AT模式

1、测试指令：(34 脚置高一次)

下行指令	响应	参数
AT\r\n	OK	无

2、模块复位（重启）：(34 脚置高一次)

下行指令	响应	参数
------	----	----



AT+RESET\r\n	OK	无
--------------	----	---

3、获取软件版本号：(34 脚一直置高)

下行指令	响应	参数
AT+VERSION?\r\n	+VERSION: <Param>	Param: 软件版本号

举例说明：

AT+VERSION?\r\n

返回+VERSION:2.0-20100601

4、恢复默认状态：(34 脚置高一次)

下行指令	响应	参数
AT+ORGL\r\n	OK	无

5、查询一蓝牙地址码：(34 脚置高一次)

下行指令	响应	参数
AT+ADDR?\r\n	+ ADDR:<Param>OK	Param:地址码

蓝牙地址表示方法：NAP：UAP：LAP（十六进制）

例：蓝牙模块地址为：11:22:33:44:55:66

发送 AT+ADDR?\r\n

返回 +ADDR:1122:33:445566 OK

11:22:33:44:55:66为查询所获取的实际地址码。

注：查询蓝牙地址返回时，地址格式分为 3 段(NAP：UAP：LAP)。第 1 段 NAP 是前面 4 个字节（前面位为零不显示），第 2 段 UAP 是中间 2 个字节（前面位为零不显示），第 3 段 LAP 是后面 6 个字节（前面位为零则显示）

6、设置/查询设备名称：(34 脚一直置高)

下行指令	响应	参数
AT+NAME=<Param>\r\n	OK	
AT+NAME?\r\n	1、+NAME:<Param> ok——成功 2、FAIL——失败	Param: 所要设置的当前名称，即蓝牙被搜索到的名称。18 个字符以内。 出厂名称：“HC-05”

例：



发送 AT+NAME=1234\r\n——设置模块设备名为：“1234”

返回 OK

发送：AT+NAME?\r\n——查询模块设备名

返回：+NAME:1234

OK

7、设置/查询—配对码：(34 脚置高一次)

下行指令	响应	参数
AT+PSWD=<Param>\r\n	OK	Param: 配对码默认名称: “1234”
AT+ PSWD?\r\n	+PSWD:<Param>OK	

查询-串口参数 (34 脚置高一次)

下行指令	响应	参数
AT+UART=<Param>, <Param2>, <Param3>\r\n	OK	Param1: 波特率 (bits/s) 取值如下 (十进制): 2400、4800、9600、19200、 38400、57600、115200、 230400、460800、 921600、1382400 Param2: 停止位 0——1 位 1——2 位 Param3: 校验位 0——None 1——Odd 2——Even 默认设置: 9600, 0, 0
AT+ UART?\r\n	+UART=<Param1>, <Param2> , <Param3>OK	

0, 2 位停止位, Even 校验

发送: AT+UART=115200, 1, 2, \r\n

返回: OK

发送: AT+UART?\r\n

返回: +UART:115200, 1, 2 OK



9、设置 PIO 单端口输出 (34 脚置高一次)

下行指令	响应	参数
AT+PIO=<Param1>, <Param2>, <Param3>\r\n	OK	Param1: PIO 端口 (1端口, 3端口) Param2: 端口序号 Param3: PIO 端口输出状态 0——低电平 1——高电平

注意: BT04-E05为用户提供 PIO 端口资源, P10~P12, P34~P35用户可用来扩展输出口

举例:

1、PIO 端口输出高电平

发送: AT+PIO=1, 0, 1\r\n

返回: OK

2、PIO 端口输出低电平

发送: AT+PIO=1, 0, 0\r\n

返回: OK

10、查询/设置—服务SERVICE UUID 默认:FFE0 (34 脚置高一次)

下行指令	响应	参数
(查询) AT+UUID\r\n	+UUID=<Param>	Param: UUID号
(设置) AT+UUID<Param>\r\n	OK	

例: 修改/查询服务UUID

发送: AT+UUID\r\n

返回: +UUID=FFE0

发送: AT+UUIDFFE1

返回: OK

注意: UUID设置以后, 需要复位操作后设置才会生效。

11、查询/设置— NOTIFY UUID\ READ UUID 默认:FFE1 (34 脚置高一次)

下行指令	响应	参数
(查询) AT+CHAR\r\n	+CHAR=<Param>	Param: UUID号
(设置) AT+CHAR<Param>\r\n	OK	

例: 修改/查询 NOTIFY UUID\ READ UUID



发送: AT+CHAR\r\n

返回: +CHAR=FFE0

发送: AT+CHARFFE1

返回: OK

注意: UUID设置以后, 需要复位操作后设置才会生效。

12、查询/设置— WRITE UUID 默认: FFE2 (34 脚置高一次)

下行指令	响应	参数
(查询) AT+WRITE\r\n	+WRITE=<Param>	Param: UUID号
(设置) AT+WRITE<Param>\r\n	OK	

例: 修改/查询写入WRITE UUID 发

送:

AT+WRITE\r\n

返回: +WRITE=FFE2

发送: AT+WRITEFFE1\r\n

返回: OK

注意: UUID设置以后, 需要复位操作后设置才会生效。

13、查询/设置—广播间隔 默认: 0 (34 脚置高一次)

下行指令	响应	参数
(查询) AT+ADVI\r\n	+ADVI=<Param>	Param: 广播间隔0 —100ms 1—152.5ms 2—211.25ms 3—318.75ms 4—417.5ms 5—546.25ms 6—760ms 7—852.5ms 8—1022.5ms 9—1285ms A—2000ms B—3000ms C—4000ms D—5000ms
(设置) AT+ADVI<Param>\r\n	+ADVI=<Param>OK	



		E—6000ms F—7000ms 默认设置： 0
--	--	---------------------------------

例：修改/查询广播间隔

发送：AT+ADVI\r\n

返回：+AVDI=0

发送：AT+AVID1\r\n

返回：+AVDI=1

OK

(对应152.5ms)

注意：广播间隔设置以后，需要复位操作后才会生效。

十四 . 联系我们

深圳大夏龙雀科技有限公司

地址：深圳市宝安区固戍二路裕兴科技园(裕兴创谷)C 栋 511

电话：0755-2997 8125

传真：0755-2997 8369

网址：<http://www.szdx-smart.com/>



Table of Contents

1、 Overview.....	20
2、 Module default parameters.....	20
3、 Application area:	21
4、 Power consumption parameters:	22
5、 RF characteristics.....	22
6、 Transparent transmission parameters.....	22
7、 Module pin description and minimum circuit diagram.....	23
8、 Pin function description:	24
9、 Other configuration.....	25
10、 Dimensions:	25
11、 LAYOUT considerations.....	26
12、 BT04-E06(HC06) AT COMMAND.....	26
12.1、 Test Command:	26
12.2、 Set/Query Device Name:	26
12.3、 Set/Query-Pairing password:	27
12.4、 Set/Query - Serial Port Baud Rate:	27
12.5、 Get The Software Version:	28
12.6、 Software restart:	28
12.7、 Restore default settings :	28
12.8、 Query Module Bluetooth MAC:	28
12.9、 Settings\Query-SERVICE UUID.....	28
12.10、 Settings\Query-NOTIFY UUID.....	29
12.11、 Settings\Query-WRITE UUID.....	29
12.12、 Settings\Query - Broadcast time interval.....	30
12.13. Verification setting instruction.....	30
13、 BT04-E05(HC05) AT COMMAND.....	31
13.1、 Test Command: (34 feet high).....	31
13.2、 Software restart: (34 feet high).....	31
13.3、 Get The Software Version: (34 pin has been set high).....	31
13.4、 Restore default settings: (34 feet high).....	31
13.5、 Query Module Bluetooth MAC:	31
13.6、 Set/Query Device Name: (34 pin has been set high).....	32
13.7、 Set/Query-Pairing password: (34 feet high).....	32
13.8、 Set / Query-Serial Port Parameters (34 feet high).....	32
13.9、 Set PIO single port output (34 feet high).....	33
13.10、 Settings\Query-SERVICE UUID.....	34
13.11、 Settings\Query- NOTIFY UUID\ READ UUID.....	34
13.12、 Settings\Query-WRITE UUID.....	34
13.13、 Settings\Query - Broadcast time interval.....	35
14、 Contact us.....	36



1、 Overview

DX-BT04-E05/E06 Bluetooth module is specially built for intelligent wireless data transmission by ShenzhenDX-SMARTTechnology Co., Ltd. SPP + BLE dual-mode Bluetooth.

This module supports the UART interface and the SPP Bluetooth serial protocol. It has the advantages of low cost, small size, low power consumption, and high sensitivity of receiving and sending. It only needs to be equipped with a few peripheral components to achieve its powerful functions.

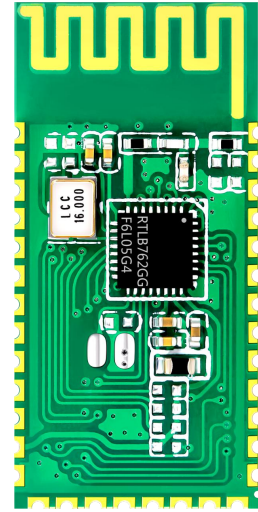

2、 Module default parameters

Bluetooth Protocol	Bluetooth Specification V3.0 SPP +V4.2 BLE
Working Frequency	2.4GHz ISM band
CommunicationInterface	UART
PowerSupply	MIN:1.8V - MAX:3.6V (Suggest 3.3V)
antenna	PCB onboard antenna
Communication distance	30-40M (Open and unobstructed environment)
Physical Dimension	27mm x 13mm x 2 mm
Physical Dimension	ROHS REACH FCC
Bluetooth Name	BT04-E05/E06 (customizable)
Pairing code	1234 (SPP agreement is valid)
Serial Port Parameters	9600, 8 data bits, 1 stop bit, No check, No flow control
Service UUID	FFE0
Notify	FFE1
Write UUID	FFE2
Storage temperature	MIN:-40°C - MAX:+140°C
Work temperature	MIN:-20°C - MAX:+85°C
Customized requirements	If you have other special function requirements, you can contact us to customize the module.



3、Application area:

The module is mainly used in the field of short-range wireless data transmission.

It can be easily connected to the Bluetooth devices of mobile phones and PCs, avoiding the cumbersome cable connection, and can directly replace the serial cable.

- ※ Bluetooth wireless data transmission
- ※ Industrial remote control, telemetry
- ※ POS system
- ※ Traffic, alarm
- ※ Automated data acquisition system
- ※ Wireless data transmission; banking system
- ※ Wireless data collection
- ※ Building automation, security, computer room equipment wireless monitoring, access control system;
- ※ Smart home, industrial control;
- ※ medical instruments
- ※ Electronic scale
- ※ Bluetooth printer, meow machine
- ※ Bluetooth remote control toys
- ※ Automotive testing equipment
- ※ Car diagnostic system OBDII



4、Power consumption parameters:

DC-DC	Average Current	Unit
Discoverable	4	mA
Connected(BLE)	4	mA
Connected(SPP)	9	mA

5、RF characteristics

Rating	Value	Unit
Basic Rate Transmit power	0	dBm
Basic Rate Sensitivity	-90	dBm
BLE Transmit power	0	dBm
BLE Sensitivity	-93	dBm

6、Transparent transmission parameters

BT04-E05/E06 dual-mode SPP data throughput:

Android ->BT04-E05/E06-> UART	UART ->BT04-E05/E06 -> Android	BAUD
11500 bytes/s	4500 bytes/s	115200

BT04-E05/E06 dual-mode BLE data throughput:

IPhone 6 ->BT04-E05/E06 -> UART		UART ->BT04-E05/E06 -> IPHONE 6	
Baud rate	115200	Baud rate	115200
Connection interval(ms)	15	Connection interval(ms)	15
APP packet size(bytes)	80	Serial packet size (bytes)	80
Send interval(ms)	50	Send interval(ms)	70
Throughput(bytes/s)	5500	Throughput(bytes/s)	2500
Characteristic Write	Write without Response	Characteristic Write	Notify



7、Module pin description and minimum circuit diagram

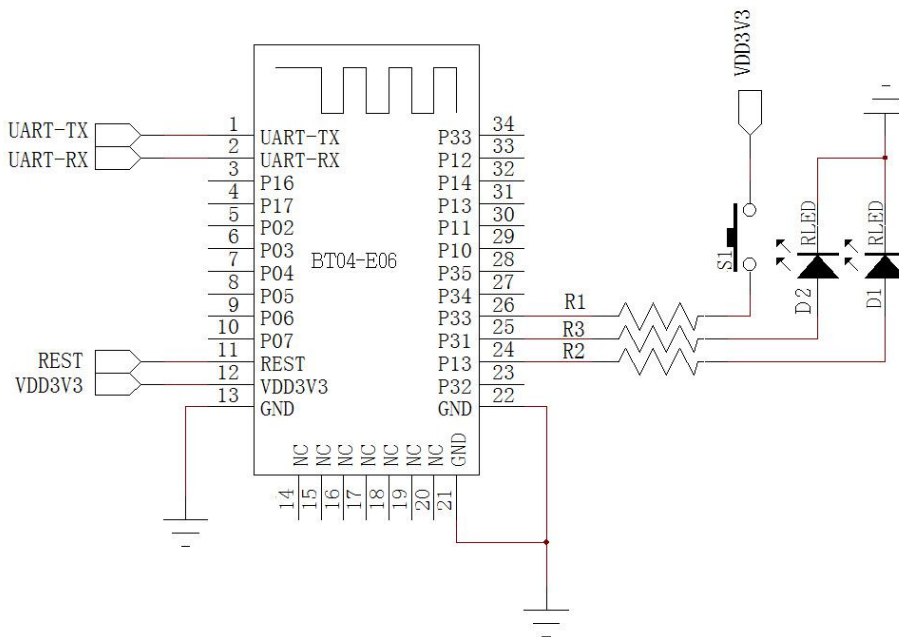
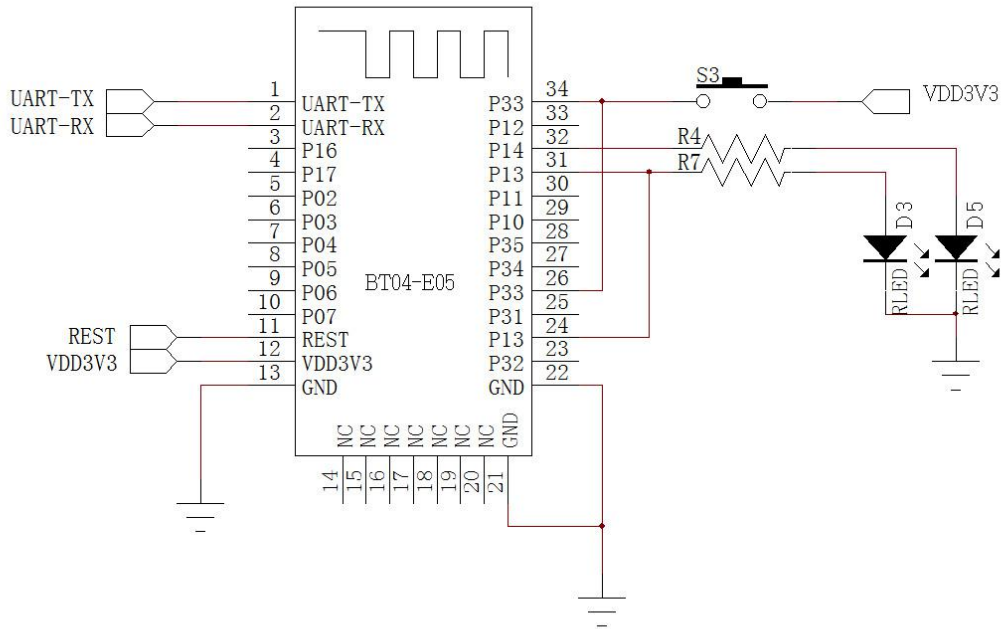

Note: The application circuit diagram is a Bluetooth serial port circuit. If you need other application solutions, please contact our company



8、Pin function description:

Pinnumber	Pin name	Types of	Pin description
1	UART-TX	CMOS output	Serial port data output
2	UART-RX	CMOS input	Serial port data input
3	NC	Bidirectional	NC
4	NC	Bidirectional	NC
5	P02	Bidirectional	Programmable input and output port
6	P03	Bidirectional	Programmable input and output port
7	P04	Bidirectional	Programmable input and output port
8	P05	Bidirectional	Programmable input and output port
9	P06	Bidirectional	Programmable input and output port
10	P07	Bidirectional	Programmable input and output port
11	RESET	CMOS input	Reset/Restart Key (Low Reset)
12	3.3V	power input	+3.3V power supply
13	GND	Land	Land
14	NC	Bidirectional	NC
15	NC	Bidirectional	NC
16	NC	Bidirectional	NC
17	NC	Bidirectional	NC
18	NC	Bidirectional	NC
19	NC	Bidirectional	NC
20	NC	Bidirectional	NC
21	GND	Land	Land
22	GND	Land	Land
23	KEY	Bidirectional	Disconnectable (BT04-E06 effective)
24	P31	output	Module Status Indicator (BT04-E06 Valid)
25	P13	output	Module Disconnect Indicator (BT04-E06 Valid)
26	P33	Bidirectional	Default Grounding, Pull High to Enter AT Mode (BT04-E05 Valid)
27	P34	Bidirectional	Programmable input and output port
28	P35	Bidirectional	Programmable input and output port
29	P10	Bidirectional	Programmable input and output port
30	P11	Bidirectional	Programmable input and output port



31	P13	Bidirectional	Module Status Indicator (BT04-E05 Valid)
32	P14	Bidirectional	Module Disconnect Indicator (BT04-E05 Valid)
33	P12	Bidirectional	NC
34	KEY	Bidirectional	Enter AT instruction mode (see AT instruction set description for details, BT04-E05 is valid)

9、Other configuration

Status indicator LED: P13

It is used to indicate the status of the Bluetooth module. The flashing mode of the LED light corresponds to the status of the Bluetooth module. See the table below:

mode	LED display	Module status
Standby	Flashes slowly and evenly (500ms-on, 500ms-off)	Waiting for pairing
	Long bright	establish connection

Bluetooth module disconnect indication: P31

Used to indicate whether the Bluetooth module is connected, the connection status is high, and the other status is low.

10、Dimensions:

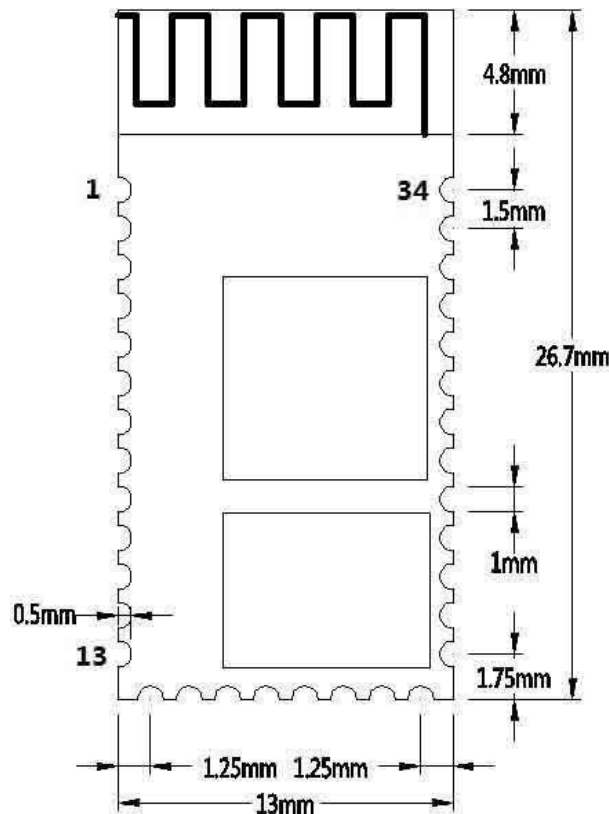



11、LAYOUT considerations

1. The serial port level of the DX-BT04-E05/E06 Bluetooth module needs to be 3.3V. If it is connected to a 5V level system, a level conversion chip needs to be added.
2. The Bluetooth signal is greatly affected by the surroundings. Obstacles such as trees, metals, walls, etc. will absorb or shield the Bluetooth signal to a certain extent, so it is recommended not to install it in a metal enclosure.
3. Since metal will weaken the antenna function, it is recommended not to lay the ground and wiring under the module antenna when giving the module Lay board, it is best to be hollowed out.

12、 BT04-E06 (HC06) AT COMMAND

Users can communicate with the DX-BT04-E05/E06 Bluetooth module through the serial port. The serial port uses Tx and Rx signal lines

Baud rate support 2400, 4800, 9600, 19200, 38400, 57600, 115200bps

Serial port default baud rate 9600bps

Detailed instruction set description (AT mode when the module is not connected, and transparent transmission mode when connected)

DX-BT04-E05/E06 Bluetooth serial port module command is Command command set.

(Note: If the module is powered on and is not paired, it will be in AT mode. The AT command can only take effect when the module is not connected. Once the Bluetooth module is connected to the equipment, the Bluetooth module will enter the data transparent transmission mode.)

12.1、 Test Command:

Down command	response	parameter
AT	OK	no

12.2、 Set/Query Device Name:

Down command	response	parameter
AT+NAME	+NAME=<Param>	Parameter name: The current



AT+NAME<Param>	OKsetname	name to be set, that is, the name that Bluetooth is searched for. Within 18 characters.
----------------	-----------	---

Example: Modify the name of the Bluetooth device 1234

Send: AT + NAME1234

Return: OKsetname

At this time, the Bluetooth name is changed to 1234

Parameters can be saved after power-off.

12.3、Set/Query-Pairing password:

Down command	response	parameter
AT+PIN	+PIN=<Param>	Param: Default name of the pairing code: "1234"
AT+ PINxxxx	OKsetPIN	

le: Modify the pairing code to 8888

Send: AT + PIN8888

Return:OKsetPIN

At this time, the Bluetooth pairing password is changed to 8888, and the module's default pairing password is 1234.

Parameters can be saved after power-off.

12.4、Set/Query - Serial Port Baud Rate:

Down command	response	parameter
AT+BAUD	+BAUD=<Param>	2---2400
AT+BAUD2	OK2400	3---4800
		4---9600
		5---19200
		6---38400
		7---57600
		8---115200
		default: 4---9600

Example: Modify the baud rate to 38400

Send: AT + BAUD6 Return: OK38400



At this time the baud rate is 38400

Note: After the baud rate is changed, if it is not the default 9600, the parameter setting or data communication is required to use the set baud rate.

12.5、Get The Software Version:

Down command	response	parameter
AT+VERSION	+VERSION=<Param>	Param: Software version number

Example:

AT+VERSION

+VERSION=2.0-20100601

12.6、Software restart:

Down command	response	parameter
AT+RESET	OK	No

12.7、Restore default settings :

Down command	response	parameter
AT+DEFAULT	OK	No

12.8、Query Module Bluetooth MAC:

Down command	response	parameter
AT+LADDR	+ LADDR =<Param>	Param:address code

example:

Send: AT + LADDR

Return: + LADDR = 11: 22: 33: 44: 55: 66

11: 22: 33: 44: 55: 66 is the actual address code obtained from the query.

12.9、Settings\Query-SERVICE UUID

default:FFE0

Down command	response	parameter
(Inquire) AT+UUID	+UUID=<Param>	Param: UUID number
(Set up) AT+UUID<Param>	OK	



Example: Modify / Query Service UUID

Send: AT + UUID

Returns: + UUID = FFE0

Send: AT + UUIDFFE1

Return: OK

Note: After the UUID is set, the setting will take effect after a reset operation.。

12.10、Settings\Query-NOTIFY UUID

default:FFE1

Down command	response	parameter
(Inquir) AT+CHAR	+CHAR=<Param>	Param: UUID number
(Set up) AT+CHAR<Param>	OK	

Example: Modify / Query NOTIFY UUID \ READ UUID

Send: AT + CHAR

Returns: + CHAR = FFE0

Send: AT + CHARFFE1

Returns: OK

Note: After the UUID is set, the setting will take effect after a reset operation.。

12.11、Settings\Query-WRITE UUID

default: FFE2

Down command	response	parameter
(Inquir) AT+WRITE	+WRITE=<Param>	Param: UUID number
(Set up) AT+WRITE<Param>	OK	

Example: Modify / Query write to WRITE UUID Send:

AT + WRITE

return:+ WRITE = FFE2

send:AT + WRITEFFE1

return: OK

Note: After the UUID is set, the setting will take effect after a reset operation.



12.12、Settings\Query - Broadcast time interval

default: 0

Down command	response	parameter
(Inquir) AT+ADVI	+ADVI=<Param>	Param: 广播间隔0
(Set up)AT+ADVI<Param>	+ADVI=<Param>OK	—100ms 1—152.5ms 2—211.25ms 3—318.75ms 4—417.5ms 5—546.25ms 6—760ms 7—852.5ms 8—1022.5ms 9—1285ms A—2000ms B—3000ms C—4000ms D—5000ms E—6000ms F—7000ms default setting: 0

Example: modify / query broadcast interval

Send: AT + ADVI

Return: + AVDI = 0

Send AT + AVID1

Return: + AVDI = 1 OK

(Corresponds to 152.5ms)

Note: After the broadcast interval is set, it needs to be reset to take effect.

12.13.Verification setting instruction

Down command	response	parameter
AT+PN	OK None	No check: The module defaults to no check
AT+PE	OK Even	Even parity: Module is even parity
AT+PO	OK Odd	Odd parity: Module is odd parity bit



13、BT04-E05 (HC05) AT COMMAND

How the module enters AT mode

- 1、 When the module is powered on, it is in AT mode when it is not paired. The baud rate is the baud rate of the module itself. The default is 9600. When sending AT commands, you need to set PIO11 high once.
- 2、 After PIO11 is set to high level, then power on the module, at this time the module enters AT mode, the baud rate is fixed at: 38400, you can directly send AT commands (**Note: When the user forgets the baud rate of the module itself, the second method is used to fix it to 38400. Usually the user is recommended to use the first method to enter AT mode!**)

13.1、 Test Command: (34 feet high)

Down command	response	parameter
AT\r\n	OK	NO

13.2、 Software restart: (34 feet high)

Down command	response	parameter
AT+RESET\r\n	OK	NO

13.3、 Get The Software Version: (34 pin has been set high)

Down command	response	parameter
AT+VERSION?\r\n	+VERSION: <Param>	Param: Software version number

for example:

AT + VERSION?\r\n

Return + VERSION:2.0-20100601

13.4、 Restore default settings: (34 feet high)

Down command	response	parameter
AT+ORGL\r\n	OK	无

13.5、 Query Module Bluetooth MAC: (34 feet high)

Down command	response	parameter
AT+ADDR?\r\n	+ADDR:<Param>OK	Param:address code

Bluetooth address representation method: NAP: UAP: LAP (hexadecimal)



Example: Bluetooth module address is: 11: 22: 33: 44: 55: 66

Send: AT + ADDR? \r\n

Return: + ADDR: 1122: 33: 445566

11: 22: 33: 44: 55: 66 is the actual address code obtained from the query.

Note: When the Bluetooth address is returned, the address format is divided into 3 segments (NAP: UAP: LAP). The first segment NAP is the first 4 bytes (the front bit is zero is not displayed), the second segment UAP is the middle 2 bytes (the front bit is zero is not displayed), and the third segment LAP is the last 6 bytes (front Displayed when the bit is zero)

13.6、Set/Query Device Name: (34 pin has been set high)

Down command	response	parameter
AT+NAME=<Param> \r\n	OK	Param: The current name to be set is the name that Bluetooth is searched for. Within 18 characters. Factory name: "HC-05"
AT+NAME?\r\n	1、+NAME:<Param> ok——success 2、FAIL——failure	

example:

Send: AT + NAME = 1234\r\n——Set the module device name: "1234"

Return: OK

Send: AT + NAME?\r\n——Query module device name

Return: + NAME: 1234

OK

13.7、Set/Query-Pairing password: (34 feet high)

Down command	response	parameter
AT+PSWD=<Param>\r\n	OK	Param: Default name of the pairing code: "1234"
AT+ PSWD?\r\n	+PSWD:<Param>OK	

13.8、Set / Query-Serial Port Parameters (34 feet high)

Down command	响应	parameter
AT+UART=<Param>, <Param2>, <Param3>\r\n	OK	Param1: Baud rate (bits/s)



<p>AT+ UART?\r\n</p>	<p>+UART=<Param1>,<Param2> ,<Param3>OK</p>	<p>The values are as follows (decimal): 2400、4800、9600、19200、 38400、57600、115200、 230400、460800、 921600、1382400 Param2: Stop bit 0——1 person 1——2 person Param3: Check Digit 0——None 1——Odd 2——Even default setting: 9600, 0, 0</p>
----------------------	--	---

Examples:

Set the serial port baud rate: 115200, 2 stop bits, Even check

Send: AT + UART = 115200,1,2, \ r \ n

Return: OK

Send: AT + UART?\r\n

Return: + UART: 115200,1,2 OK

13.9、Set PIO single port output (34 feet high)

Down command	response	parameter
<p>AT+PIO=<Param1>,<Param2>,<Param3>\r\n</p>	<p>OK</p>	<p>Param1: PIO port (1port, 3port) Param2: Port number Param3: PIO 端口输出状态 0——Low level 1——High level</p>

Note: BT04-E05 provides users with PIO port resources, P10 ~ P12, P34 ~ P35 users can be used to expand output

for example:

1、PIO port output high level

Send: AT+PIO=1, 0,1\r\n

Return: OK

2、PIO port output low level

Send: AT+PIO=1, 0,0\r\n

Return: OK



13.10、Settings\Query-SERVICE UUID (34 feet high)

default:FFE0

Down command	response	parameter
(Inquire) AT+UUID\r\n	+UUID=<Param>	Param: UUID number
(Set up) AT+UUID<Param>\r\n	OK	

Example: Modify / Query Service UUID

Send: AT + UUID

Returns: + UUID = FFE0

Send: AT + UUIDFFE1

Return: OK

Note: After the UUID is set, the setting will take effect after a reset operation.

13.11、Settings\Query- NOTIFY UUID \ READ UUID (34 feet high)

default:FFE1

Down command	response	parameter
(Inquire) AT+CHAR\r\n	+CHAR=<Param>	Param: UUID number
(Set up) AT+CHAR<Param>\r\n	OK	

Example: Modify / Query NOTIFY UUID \ READ UUID

Send: AT + CHAR\r\n

Returns: + CHAR = FFE0

Send: AT + CHARFFE1\r\n

Returns: OK

Note: After the UUID is set, the setting will take effect after a reset operation. .

13.12、Settings\Query-WRITE UUID (34 feet high)

default: FFE2

Down command	response	parameter
(Inquire) AT+WRITE\r\n	+WRITE=<Param>	Param: UUID number
(Set up) AT+WRITE<Param>\r\n	OK	

Example: Modify / Query write WRITE UUID



send: AT + WRITE \r\n

return: + WRITE = FFE2

send: AT + WRITEFFE1 \r\n

return: OK

Note: After the UUID is set, the setting will take effect after a reset operation.

13.13、Settings\Query - Broadcast time interval (34 feet high)

default: 0

Down command	response	parameter
(Inquire) AT+ADVI\r\n	+ADVI=<Param>	Param: Broadcast interval
(Set up) AT+ADVI<Param>\r\n	+ADVI=<Param> OK	0—100ms 1—152.5ms 2—211.25ms 3—318.75ms 4—417.5ms 5—546.25ms 6—760ms 7—852.5ms 8—1022.5ms 9—1285ms A—2000ms B—3000ms C—4000ms D—5000ms E—6000ms F—7000ms default setting: 0

Example: modify / query broadcast interval

send: AT + ADVI

return: + AVDI = 0

Send: AT + AVDI1

Return: + AVDI = 1

OK

(Corresponds to 152.5ms)

Note: After the broadcast interval is set, it needs to be reset to take effect.。



14、Contact us

ShenZhenDX-SMARTTechnology Co., Ltd.

Address: 511, Building C, Yuxing Technology Park, Yuxing Chuanggu, Bao'an District,
Shenzhen, China

Tel: 0755-2997 8125

Fax: 0755-2997 8369

Website: <http://www.szdx-smart.com/>